











( ) ) ,

<p>1 . / /</p>			
<p>1 . / /</p>		<p>2 . / /</p>	
<p>3 . - / /</p>		<p>) )</p>	
<p>/ 45</p>	<p>7</p>	<p>2 /.</p>	<p>2 ;</p>

			<p>/ 1</p> <p>/. 4 /</p> <p>· - / 1</p> <p>1 / .</p> <p>· //</p> <p>/</p>
--	--	--	---

: 7- :

-

<p>· · / /</p>	<p>· / /</p>	<p>· / /</p>	<p>/</p>	<p>/</p>
5	<p>2 .</p> <p>- 4</p> <p>/</p> <p>1</p> <p>2 - /</p>	<p>2 4</p> <p>4</p> <p>4 /</p> <p>4 /</p> <p>- /</p> <p>4.</p> <p>3 . - /</p> <p>/ 1 / 1</p> <p>4 . - / -</p> <p>4 .</p> <p>4 - /</p> <p>4 /</p> <p>1 / 1</p> <p>4 /</p> <p>- /</p>	<p>54</p> <p>54</p>	<p>- /</p>
	<p>2 .</p> <p>·</p> <p>- / 1 1</p> <p>· /</p>	<p>2 4</p> <p>4</p> <p>4 /</p> <p>3 1</p> <p>4 . / 1 .</p> <p>4 /</p> <p>4</p> <p>4</p> <p>3</p>	<p>4</p> <p>7</p>	<p>- /</p>





( ) \* ( ) ,

0	1	0	1	1
2				3
+	45	68 78	2 9	2

. 6

2

562 . 0 . 5 =3 7(5 ,  
 $5 \cdot 73 \cdot 7 \cdot 5 \cdot 10^2 \cdot 10^2 \cdot 10^1 \cdot 10^1 \cdot 7 \cdot 10^0 \cdot 10^0 \cdot 10^{-1} \cdot 10^{-1} \cdot 7 \cdot 10^{-2} \cdot 10^{-2}$   
 =62 5 =3 =( , 35 535(=,3

(5 ,

5 =3 =( , 5 3 8 (5 ,

5 535(=, 3 (5 ,

(5 , 5 (5 ,

762 0 555 5 3 5 5(=,3

= (5 ,

555 5 3 5 5(=, 7 3 (5 ,

= (5 , 5 5(5 ,

62

37 (5 ,35 = (5 ,

37 (5 , 55 55 3 55 5(=,

5 = (5 , 5 5(=,

62

= 8(5 ,3 375= (5 ,

= 8(5 , 5( ,

375= (5 , 3 ( ,

6 2

4 .

0

556

555555 5

8655 5535(=, 55 53 (=,

©□) + )



( ) \* ( ) ,

0	1	0	1	1
.	.	.	.	.
2				3
)		+		)
+	45	6 78	2 9	.....
				2 ; .....

I 5 5 53 5 (=,  
 6 73( , DB( ,  
 I 55=3 ( ,  
 6\_ D 3 (5D) 7 3 (5D)  
 I 7 3(5D)  
 5 65 5 53 5(=, 5555535(=,  
 I 5 53 (=,  
 5567 =3( , 4D83( ,  
 I =?=3 ( ,  
 5=6 73(5D) 4 3\_ (5D)  
 I\_ DB (5D)  
 576555 55(=, 5 5(=,  
 I 5 555555(=,  
 5 6 5 55 55(=, I 555(=,  
 I 55 5 (=,

2

56 1 7= 7=. ?5=  
 . 6 0 .

I F . 7= 7= 2<sup>5</sup>2<sup>5</sup> 2<sup>5</sup>2<sup>5</sup> 2<sup>10</sup>2<sup>10</sup>  
 . 1 ?5= 2<sup>12</sup>2<sup>12</sup>  
 0 ( . ,  
 0 . 2<sup>4</sup>2<sup>4</sup> 5D6  
 =6+ - 0 1 1 =?D  
 . 6



0	1	0	1	1
2	3			
45	6 78	2 &9	.....	2 .....

0 & 1  
c  
I  $2^l \geq 2^l \geq$  DBE 6  
76 . - 0 & d & 1 5 0 3  
TS U3 0 3 &

D 6  
I? &  
6E & P O\_ ee4  
I ( 75D P ( 5D ( 5D (? 5D (??5D (? 5D ( ?5D O  
(?=5D

5 55 5 5555 5 55 5 5 5 5 5 5  
5 5 5 5 5 5 5 5  
?6 5 5 5 5 5 5 5 5 5 5 5 55  
5 5 5 555 5 5 6  
I 2 & 66 0 66 5 \_  
= 3 \_ ee 0 . 6  
2

562 & 1 3 F  
n( n ,6 53 6

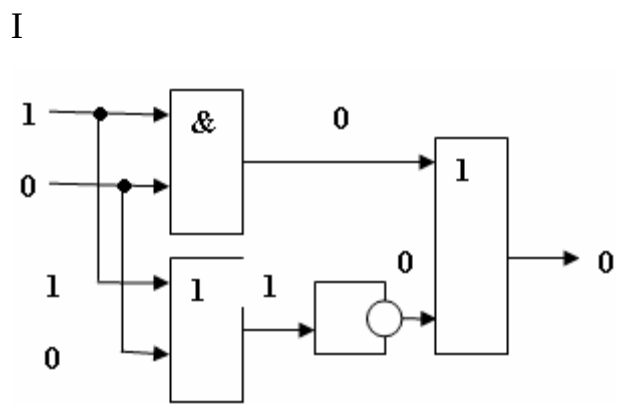



<p style="text-align: center;">&amp; &amp; ( ) ,</p> <p style="text-align: center;">&amp;- &amp;</p>			
0	1	0	1
2		3	
4	7	2 & . :::::	2 :::::

( ,

=

& 1

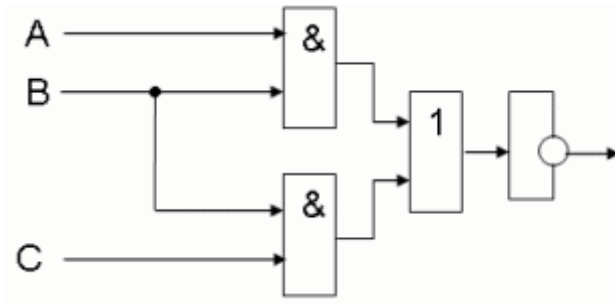

( , ( ,

7

0

(( v , ( , -

( v ,

( , →

( , → ( , ( , - - - - -

2 3

&



( ) \* ( ) ,

0	1	0	1	1	3
45	655	78	2	2	

D7 6

I

M\_ 3

M 3D

M 3

L M

M 3

M\_ 3

ML 3

L

\_LL\_ 3

6+

$$y = \frac{12+3}{8+6} * 3 + 12$$

I

M\_ 3

\_LL\_ 3

M 3

\_LL 3D

L M

M\_ 3

M 3

\_LL\_ 3

76+

$$y = \frac{5*3+13/4}{1+12/5} - 28 + \frac{13}{3}$$

I

M\_ 3

M 3

M 3

M\_ 37

M 3

L M

©□) + )



( ) ) ,

0	1	0	1	3	1
		2		-	-
45	65 78	2 9			2

M\_ 3  
 \_LL\_ 3  
 M 3  
 M\_ 3  
 M 3  
 L M  
 M\_ 3  
 \_LL\_ 3  
 M 3  
 M\_ 3  
 L M  
 M 3 B  
 \_ 3  
 M 3  
 M\_ 37  
 M 3  
 L M  
 M\_ 3  
 \_LL\_ 3

562 1 6  
 6 6  
 76 - 1 1  
 6  
 6 2 -  
 . 6 0 6  
 6 0 6 2 0  
 1 - 0 6  
 D62 1 6  
 862 - 0 1 1 6  
 B6 - 0  
 6  
 6 4 6  
 5 6 - . 6  
 556 . 0  
 6  
 5 6 2 6





( ) ) ,

1 . . 1 - 3. 1

3. -

) )

4

7



1

1

3



3

3

3.

1

1

3.

3

1

1



( ) ) ,

1 . . 1 - 3. -

) )

45

5 7



3

3

1 1

F

3

3  
1

1

3

3



C

7

3

N



( ) ) ,

1 . . 1 . . 1

3. -

6 7

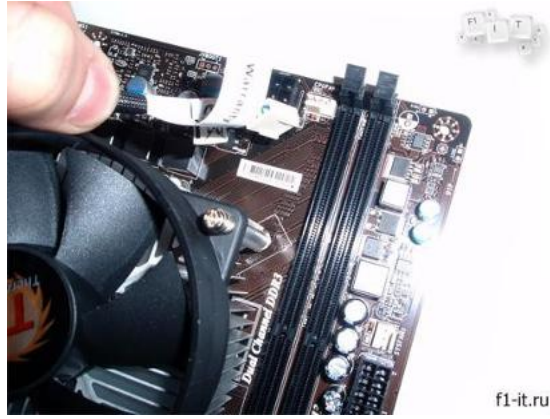

2

3

6

3 3



3

6

6

3.

3

1

6



( ) ) ,

1 . . 1 - 1

3. -

7



f1-it.ru

2 \_\_\_\_\_

1



f1-it.ru



f1-it.ru

© )

)

			
( ) ) ,			
1		1	
		3	
B 78		; :	

3 3

1 3 3



3 1 3

3 1 3

1 3

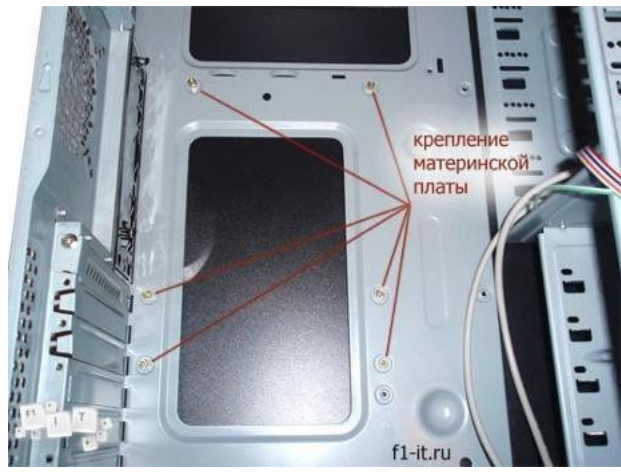



( ) ) ,

- . / /

. . . 1 . . . / / 1 - / 3. - / /			
/ ) )			
/	7	9 /.	

3 / . 3

1 / . . . . 3

. 3 d 9 / . / d // 3 . .

. . 1. / 3 9 / 3. .

. . / / 3 / 1.

. / o d / . . . 9 /

. d / . . 3 9 / . 1

. /



/ / / . / d / \_ US



/ . 3 / 3 d / o \_ US / .

3 . .



( ) ) ,

0 1 . 0 . 1 - 3 . 1  
2 ) )

7

2

2

3

1.

( Ti d

d Ti

( . LL

uaL PRaO uaL,

2 .

(

PRaO lR

Oala lR,



2

3

l o 3 \_ US

Ti .

3

3

1

3

3

1

\_\_\_\_\_



			
( ) ( ) ,			
1 . 1 - 3. 1			
2 ) )			
4	78	2 .	2

41



2

3

2

41

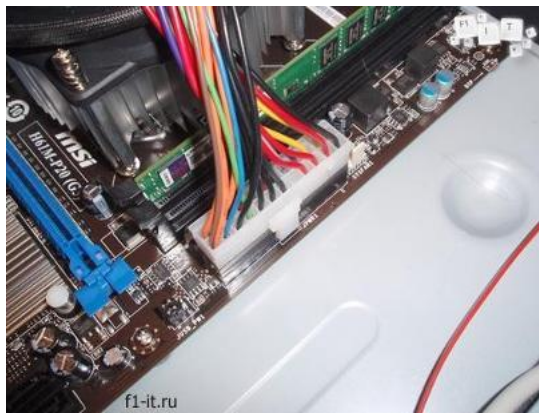

2

41

4





( ) ) ,

1 . 1 - 3. 1  
2 ) )

7

2

.....

2

.....

I

- \_ \_ 3

1



1

3.  
3



- \_ \_ 3

1 \_ \_

			
( ) ) ,			
1	2	1	3
4	7 7	2	2



f1-it.ru

3

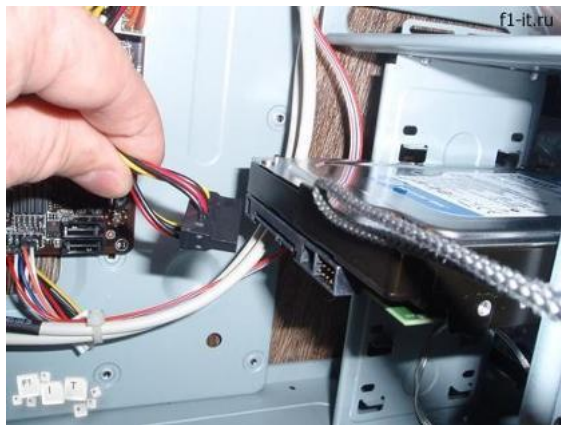

f1-it.ru

1

1

1



f1-it.ru



( ) ) ,

1 . 1 - 3. 1			
2 ) )			
45	7	2 . : : : : : : : : : : : :	2 ; : : : :

3



,  
 , . 1 .  
 , 1 . 1 2 2  
 , 1 2  
 , . .

1 1

5,

7,

2

1

3

1

3

3

3

5,

7,

© □ )

)



( ) ) ,

0	1	0	1	3	1
2					
45	78	2	9		2

, . 3. . 1 0 3  
 1. 3. . . 7 : -  
 3  
 3

. 1 - . 3  
 -

2  
 (. 0 ,3. 9 - 1 .

5, 2 3 . . 0 . 1  
 3  
 , ( , 0 4 1  
 , ( - , 5 7 4  
 , ( , 5 4  
 , .

, . 0 . .  
 . . .  
 , . .  
 , . 0  
 , .

7, 2  
 , .  
 , ..  
 ,  
 , .



( ) ) ,

1 . 2 . 1 - 3. 1			
) )			
45	6 78	2 9 .	2

, 9  
 , . . . . . -  
 , . - -  
 , . . - 1 .  
 , .  
 ,  
 ,  
 , .  
 , .

,  
 , 3 . 1 9  
 , . 1 . 9  
 , 1 3 .  
 , .

8,  
 , - .  
 , - -  
 ,  
 , .

, 1 . 3 . 1 3  
 . 3 . 1 . 1 3 1 9 1 3

, - 4  
 ,  
 , .

, ( ,3 . 3 .  
 . 3 9 4 3 d . 3



( ) ) ,

0	1	2	0	1	3	1
4	7	2				2

,  
 , -  
 , - 0  
 , .

, 1 3 . 0 3

,  
 , .  
 ,  
 , .

, . - . 0

, - 4  
 , .  
 , .  
 ,

, 1 1

,  
 , d  
 , d  
 ,

7, - 0

, -  
 , -  
 , . 0  
 , .

, 2 1 .

. . .

,  
 , 4



( ) ) ,

1 . 1			
2		3. 1	
45		6 78	2 .
2			

, 4  
, .

57,

, -  
, . - 5 4  
, . - 5 4  
, . -

5 ,

, 1 -  
, . 1 -  
, .  
, .

5 ,

3 . . .  
3  
, . .  
, 4  
, . .  
, .

5 , 2

3 - 3 6 6  
. 3  
, 4  
, 4  
,  
, .

58,

. 3 . 3  
, -  
,  
, --  
, .

5 ,



( ) ) ,

. . . . . 0 1 . 0 . 1 - / /			
. . . . . / 2 / / - / 3. - / /			
/		7	2 9 /.
			2

. 1  
 , 3 3  
 , 3 3  
 , 3 3  
 , .

, / / 1  
 , . 0  
 , . / . / /  
 , . 0 //

, . / .  
 , .  
 ,  
 , 2  
 , 3 . /

, . 0 3 . . / 1  
 . / 3 1 . 1 . / 1

1  
 , d 0  
 , d 0  
 ,  
 , .

, 0 . /  
 , .  
 , . 1  
 , . // . 0

7, / . - / / .  
 /

,  
 , . .  
 , . 1  
 , .



( ) ) ,

0	1	0	1	3	1
2					
45	67 78	2			2

, . 1

, l \_

, a l \_ -

, .

, 2

3-

, .

, .

, .

, .

D

3

( , . 6 6 . 62

, .

, 0

, .

, .

D

1

S

, .

, .

, 3

5 B

, .

8, 2

, .

, .

, .

1

, .

0

. 0



( ) ) ,

0	1	0	1	3	1
2					
7	78	2	9		2

, 9 3 . 0 3

, d  
, d  
,  
, .

, 0 . 1 -  
. 2  
, .  
, 9  
, 0  
,

7 , H

,  
, .  
,  
, .

7 , H

. .  
, 0 1 1  
, 1. 0 1  
, 1. 0 1  
, 1 1  
, 1

7 , 2

0 9  
, 3 0 - 3 3 .  
. 0  
,  
, 3 . - 0 3  
, 3 . 1  
, .

77, - . . 9

©□) )



( ) ) ,

0	1	0	1	3	1
2					
45	67 78	2			2

, . 1 1 3. 1

4 . 3. 1 .

, . 1 1 3. 1

4 . 3. 1 .

, . 1 . 1 .

, .

7 , H . 0 . .

. 0

, . 3. 5

, . 5 . 3

, . . 5 3

, . 5

, . 3.

. 5

7?, H 1 7 b7 .

?5 . 6 0 .

c

, 5D

, 5

, 7

, .

7D

, a\_ 3a 3a 3a

, a a 3a 3a 3a

, .

, .

78,

, 1 B

,

,

, 1

, 5D

©□) )



& & ( ) , &- & 0 1 . 0 . 1 1 . . . 2 - 3. - ) )			
4	677 78	2 &9 .	2

7B, 2

M\_ 3  
 \_LL\_ 3  
 M 3B  
 \_LL 3D  
 LeM  
 M\_v 3  
 M 3  
 g  
 \_LL\_ 3

, -  
 ,  
 , -  
 U .

7

7 ,

& 1

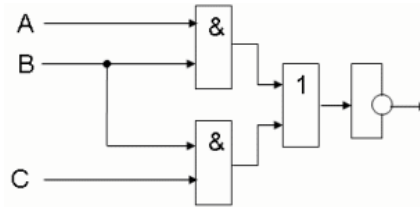

, ( \_ , M( ,  
 , ( ,  
 , ( v , ( ,  
 U .

, 2 .

( \_ , → .

,  
 ,  
 , - M  
 U .

,  
 , D  
 , B  
 , 7

1 BD



( ) ) ,

0	1	2	0	1	3	1
45	67	78	2	9		

, D

, . . . 0 D 3 (5D)  
 73D(5D)  
 , 5 3 (5D)  
 , 55 3 (5D)  
 h, 5 3 (5D)  
 , .

7, 2                      3D D 5  
 , 3  
 , 53  
 h, 35  
 , .

**3**

0	2		0	
	.	0 .	.	0 .
2 4	4 6	4 6	4 6	4 6
	4 3 9	4 3 9	4 3 9	4 3 9
	4 .	4 .	4 .	4 .
	4 -	4 -	4 -	4 -
	4 .	4 .	4 .	4 .
	4 - 0	4 - 0	4 - 0	4 - 0
	( 3 - 3 ,	( 3 - 3 ,	( 3 - 3 ,	( 3 - 3 ,
	4 -	4 -	4 -	4 -
	6	6	6	6
2 4	4. 6	4. 6	4. 6	4. 6



( ) ) ,

1 . 1 3. 1			
2 -			
) )			
5	7 7	2 .	2 ;

	<p>·</p> <p>-</p> <p>· 3</p> <p>·</p> <p>1 3 . 3</p> <p>· 1 1</p> <p>·</p> <p>· 2</p> <p>-</p> <p>·</p> <p>-</p> <p>( O 3 3 M 3 3</p> <p>· 3 1</p> <p>·</p> <p>·</p> <p>·</p> <p>1</p>	<p>·</p> <p>-</p> <p>· 3</p> <p>·</p> <p>1 3 . 3</p> <p>· 1 1</p> <p>·</p> <p>· 2</p> <p>-</p> <p>·</p> <p>-</p> <p>( O 3 3 M 3 3</p> <p>· 3 1</p> <p>·</p> <p>·</p> <p>·</p> <p>1</p>	<p>·</p> <p>-</p> <p>· 3</p> <p>·</p> <p>1 3 . 3</p> <p>· 1 1</p> <p>·</p> <p>· 2</p> <p>-</p> <p>·</p> <p>-</p> <p>( O 3 3 M 3 3</p> <p>· 3 1</p> <p>·</p> <p>·</p> <p>·</p> <p>1</p>
2	<p>R · W</p> <p>2</p> <p>· - · 2</p> <p>·</p> <p>· 3</p> <p>· 1</p> <p>· 1</p> <p>·</p> <p>- · 1</p> <p>1 ·</p> <p>·</p>	<p>R · W</p> <p>2</p> <p>· - · 2</p> <p>·</p> <p>· 3</p> <p>· 1</p> <p>· 1</p> <p>·</p> <p>- · 1</p> <p>1 ·</p> <p>·</p>	<p>R · W</p> <p>2</p> <p>· - · 2</p> <p>·</p> <p>· 3</p> <p>· 1</p> <p>· 1</p> <p>·</p> <p>- · 1</p> <p>1 ·</p> <p>·</p>



( ) ,  
 % - %  
 - . %

0	1	0	1	%	1	%
%	2	%	%	-	%3.	-
%	67	7	2	%	.....	2 ; .....

□□□□

0  
 . 1 % 3  
 . 3 . 3  
 . % %1 6 3 .  
 . 0  
 . 1 3  
 . 3 % %1 6 3 .

???

% . 0	0 %
2	
2	
% . 0 -	

,  
 • 62  
 • . % 3 . - 3 0 3 % . 0 1 % % . 3 1  
 • 0 . 3 . % .  
 1 % % % 3 . 3 0 3 1 %  
 % . % . 1 % % . 6  
 • 6  
 • . - % . 0 %  
 - 1 3 1 1 % % . 3  
 • . % .

